



SEATCRAFT

ANTHEM LT

Heat, Massage, Power Headrest, Power Lumbar, &
Power Recline Loveseat w/ Storage Console

ASSEMBLY & GENERAL USE GUIDE

Table of Contents

What's Inside the Box	2
Step 1: Connect the Remote, Massage & Power	3
Step 2: Attach the Console Backrest	4
Step 3: Attach the Backrests to the Seat Base	5
Step 4: Connect the Power Adapter Cable	6
Step 5: Attach the Tray Tables	7
Using the Power / Massage Remote Control	8
Trouble shooting Guide	9-11
Seat Part List	12-14
Proposition 65 Information	15
Important Safety Information	16
Warranty Info & Contact Information	17

What's Inside the Box

1. BACKREST
2. CONSOLE
3. BACKREST
4. TRAY TABLE
5. TRAY TABLE
6. RED BAG (Includes: Power Adapter & Power Adapter Cable)
7. RED BAG (Includes: Power Adapter & Power Adapter Cable)

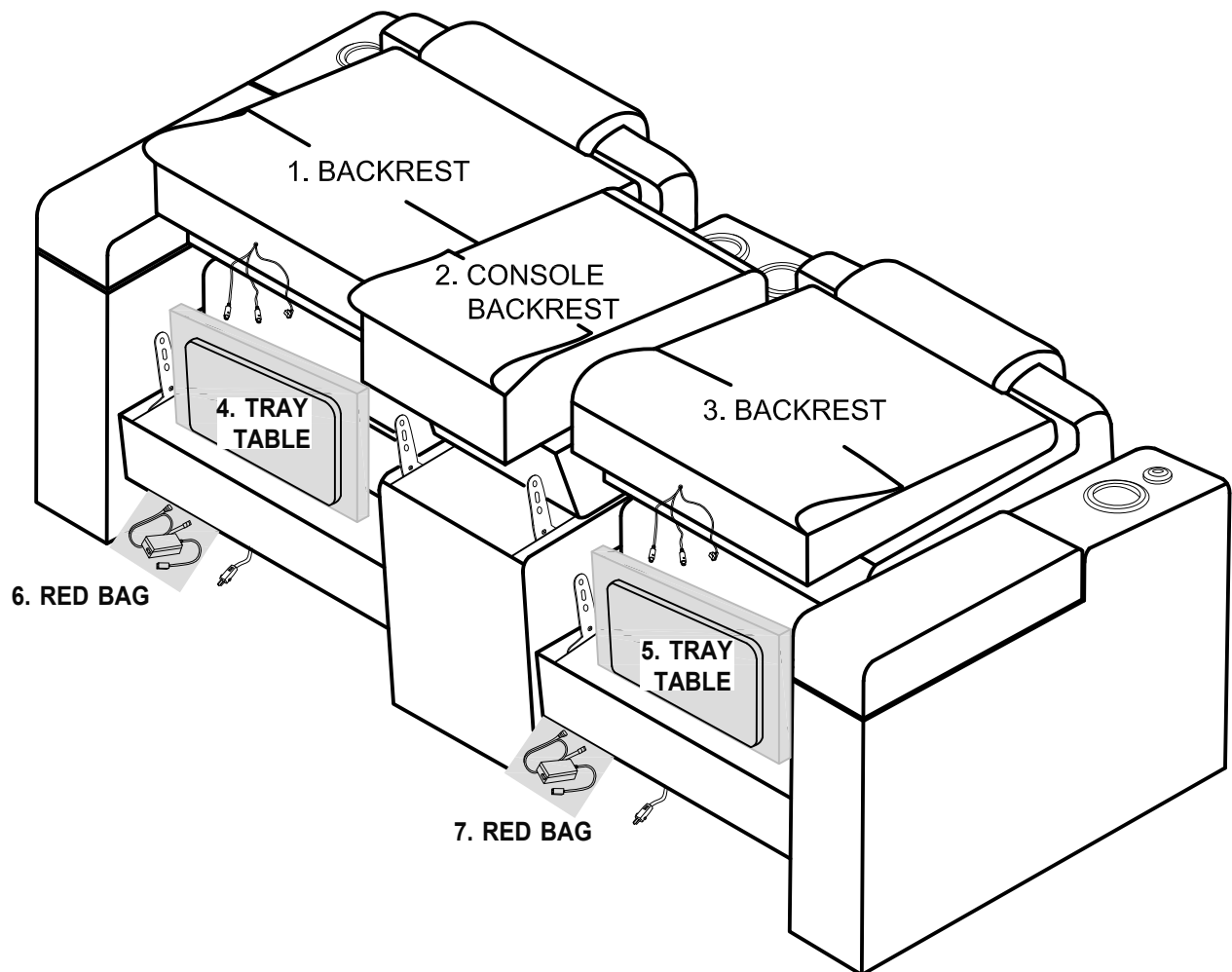

STEP 1

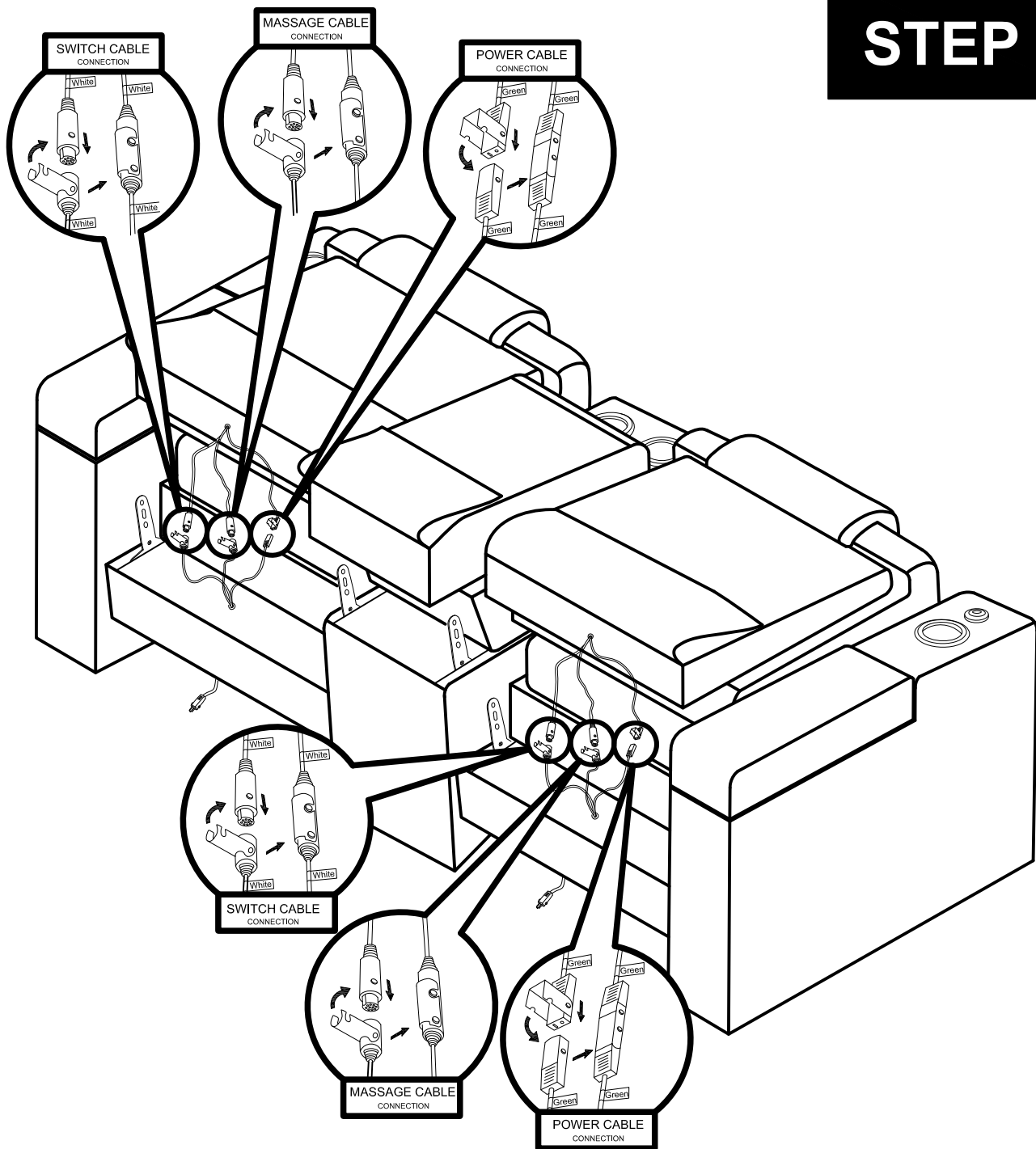

Connect the Switch, Massage, & Power Cable Connections

Connect each Switch Female Cable to the switch Male Cable.
Connect each Massage Female Cable to the Massage Male Cable. Lock both cables together.
Connect each Power Female Cable to the Power Male Cable. Lock both cables together.

STEP 2

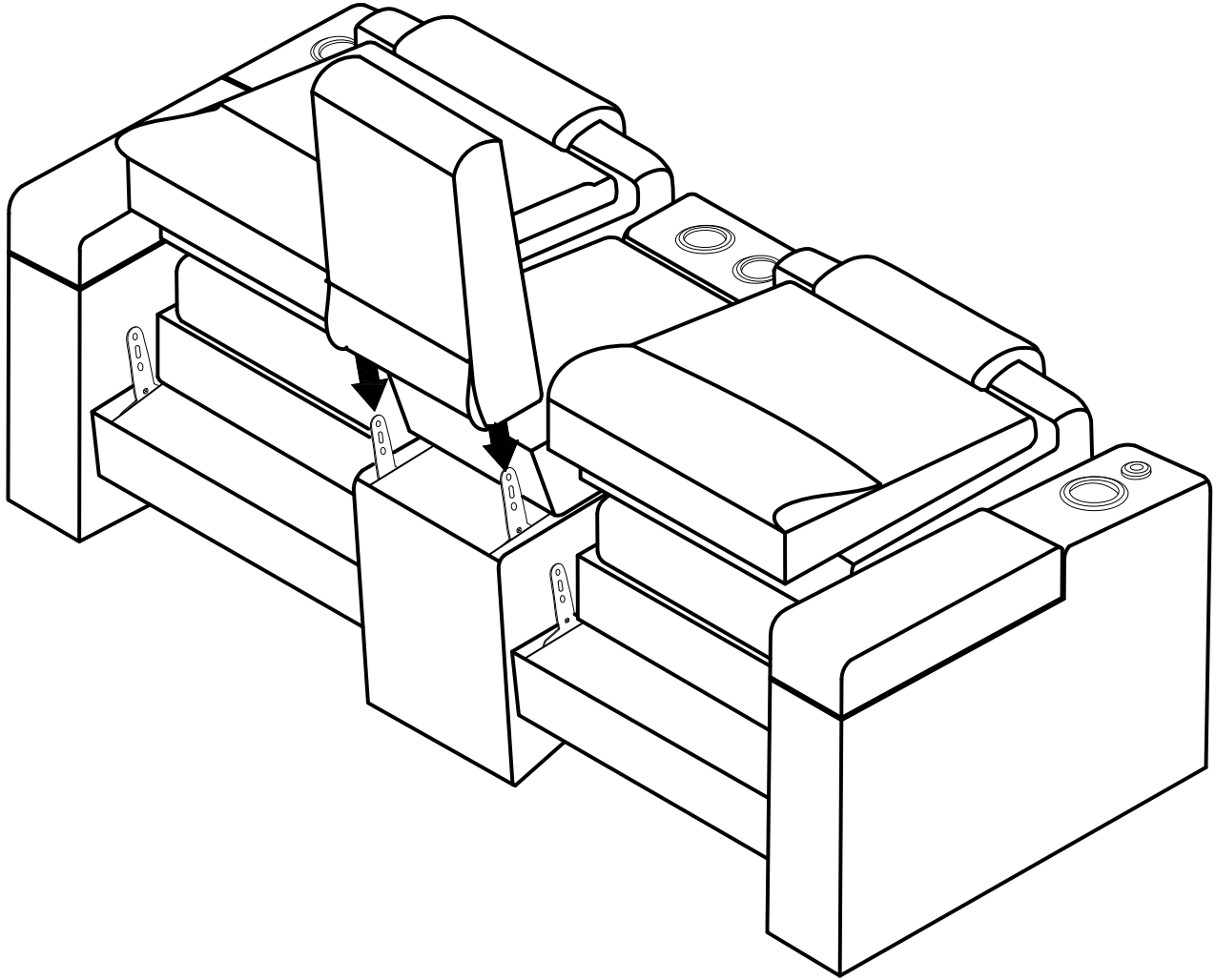

Attach the Console Backrests

Slide the Backrest Female Backrest onto the Backrest Male Brackets.
Push until you hear a click on both sides. This will indicate that each backrest is secured.

STEP 3

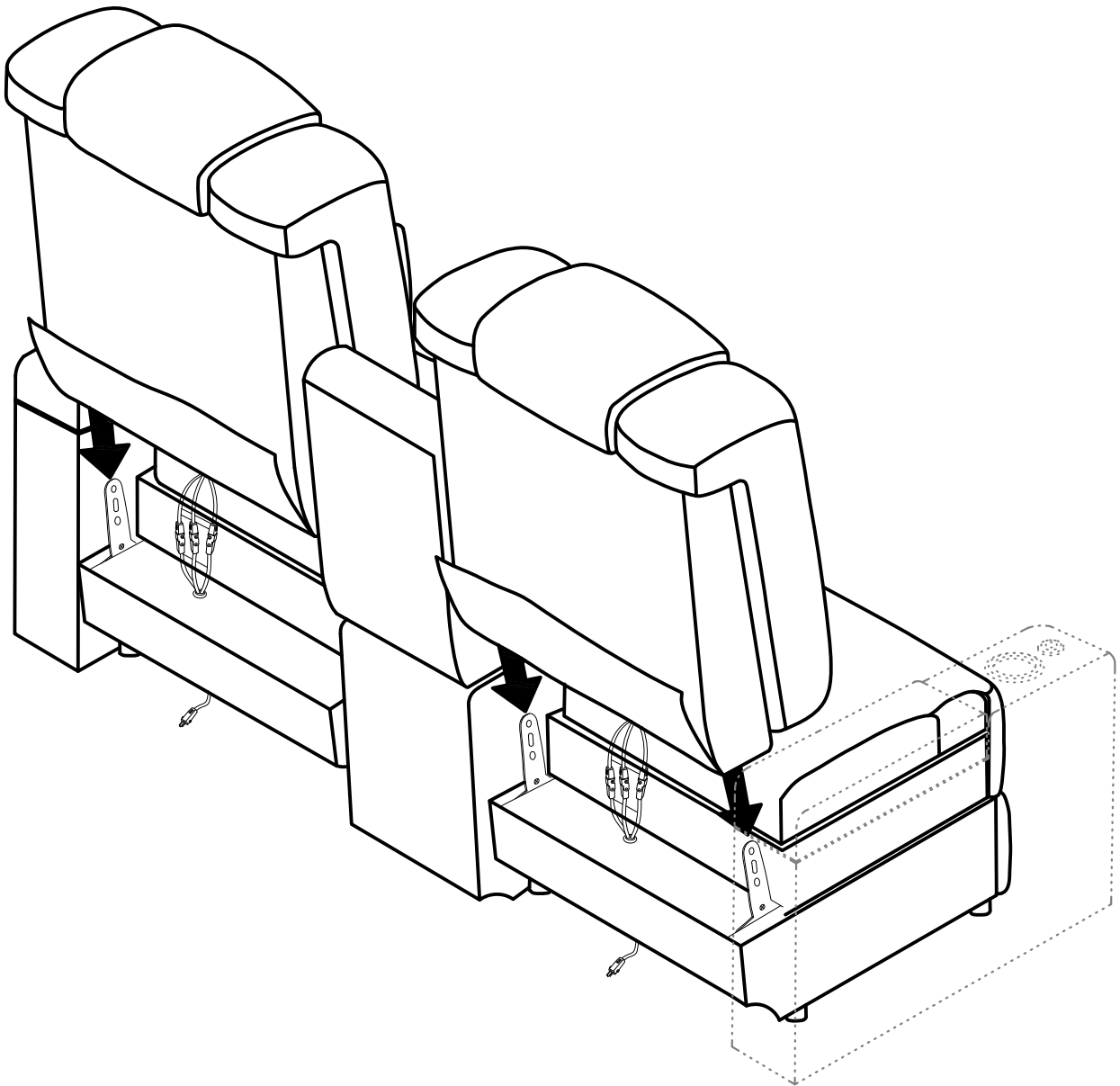

Attach the Backrests to the Seat Base

Slide the Backrest Female Backrest onto the Backrest Male Brackets.
Push until you hear a click on both sides. This will indicate that each backrest is secured.

STEP 4

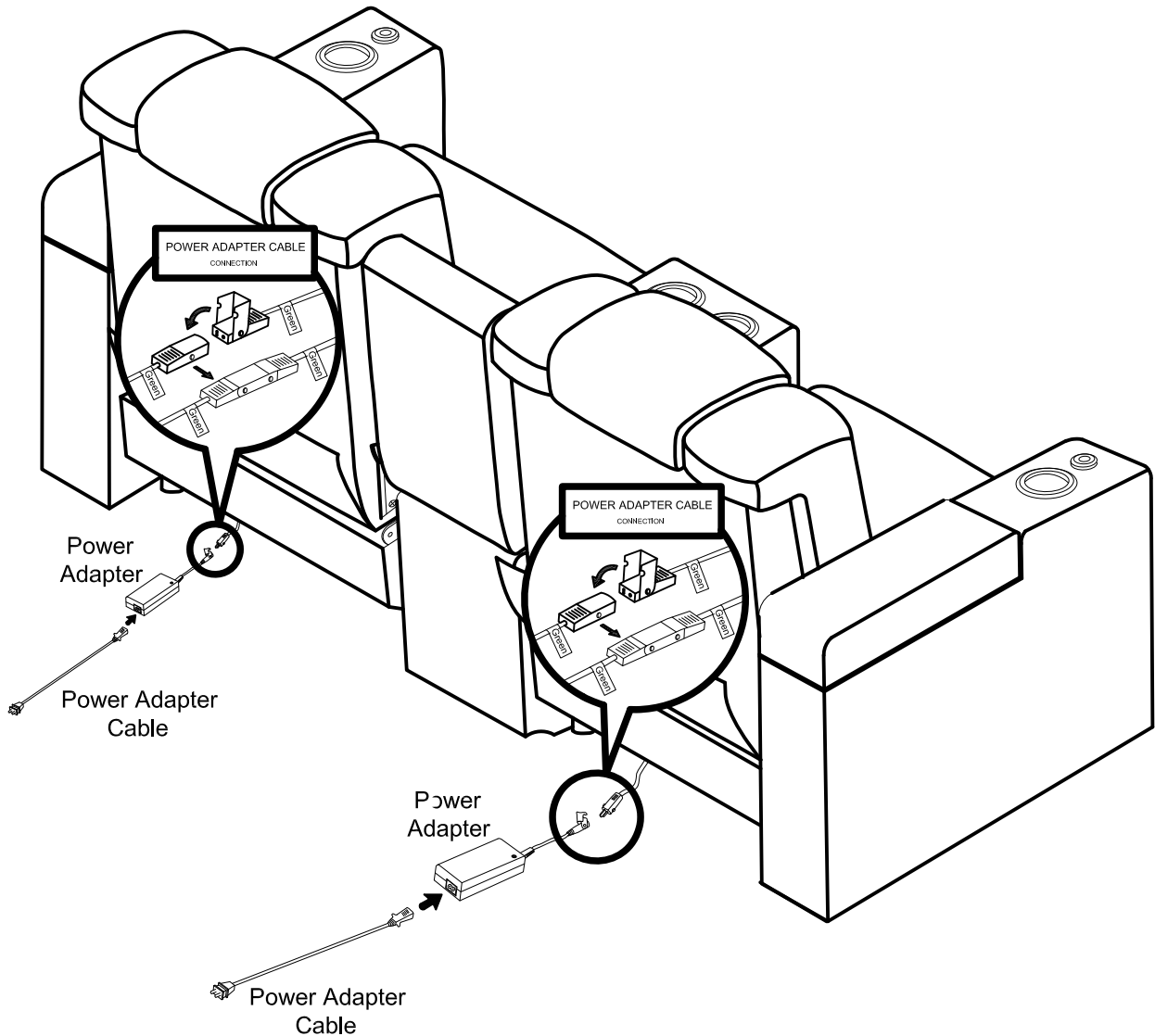

Connect the Power Cables

End Seats: Plug in the Power Adapter Cable to the Power Adapter connect a Power Adapter to each seat base. Plug in both cables to a power source.

STEP 5

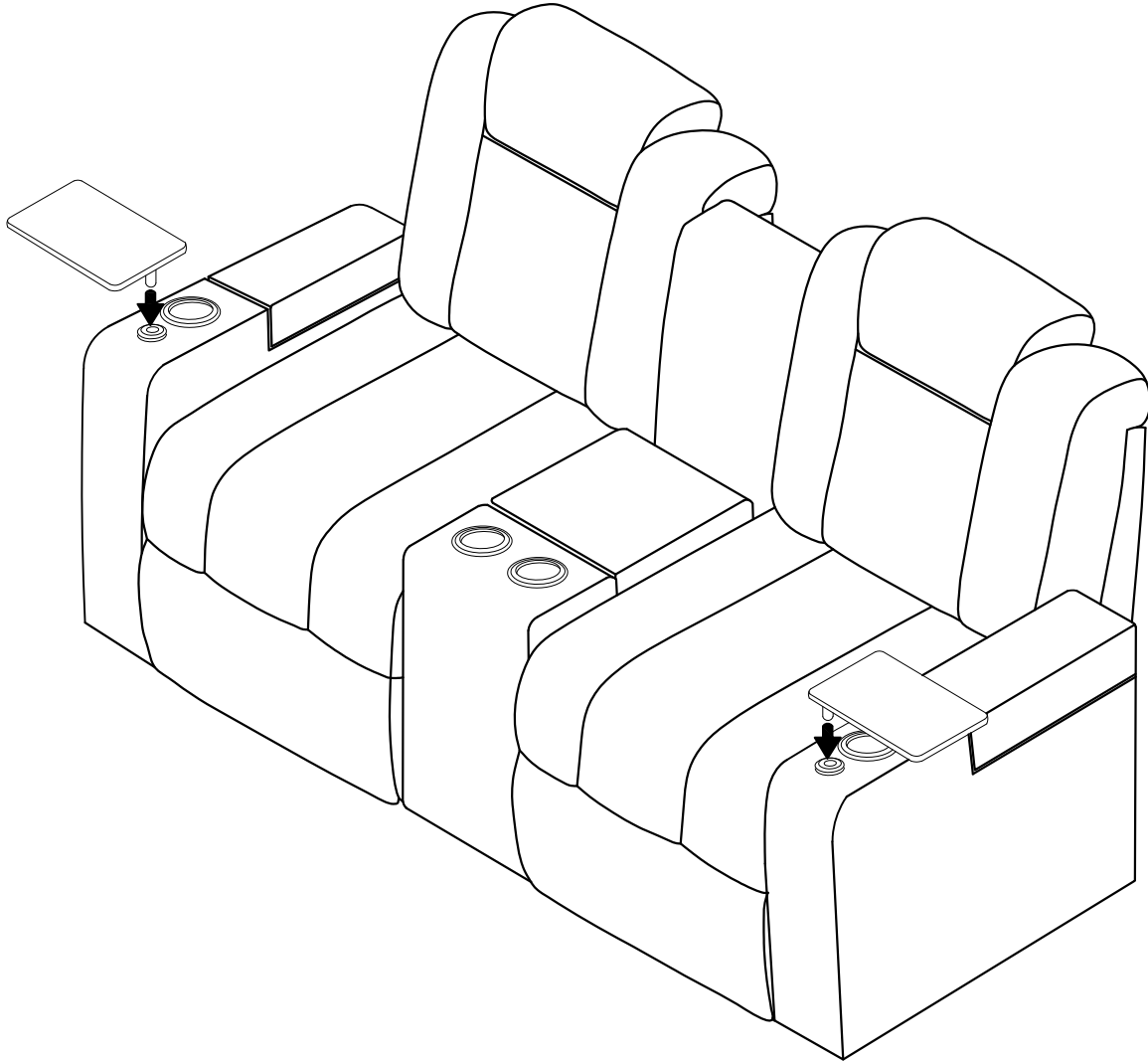

Attach the Tray Tables

Find your Tray Tables behind the seat.
Place each Tray Table into an accessory mount.

Using the Power / Massage Switch Control

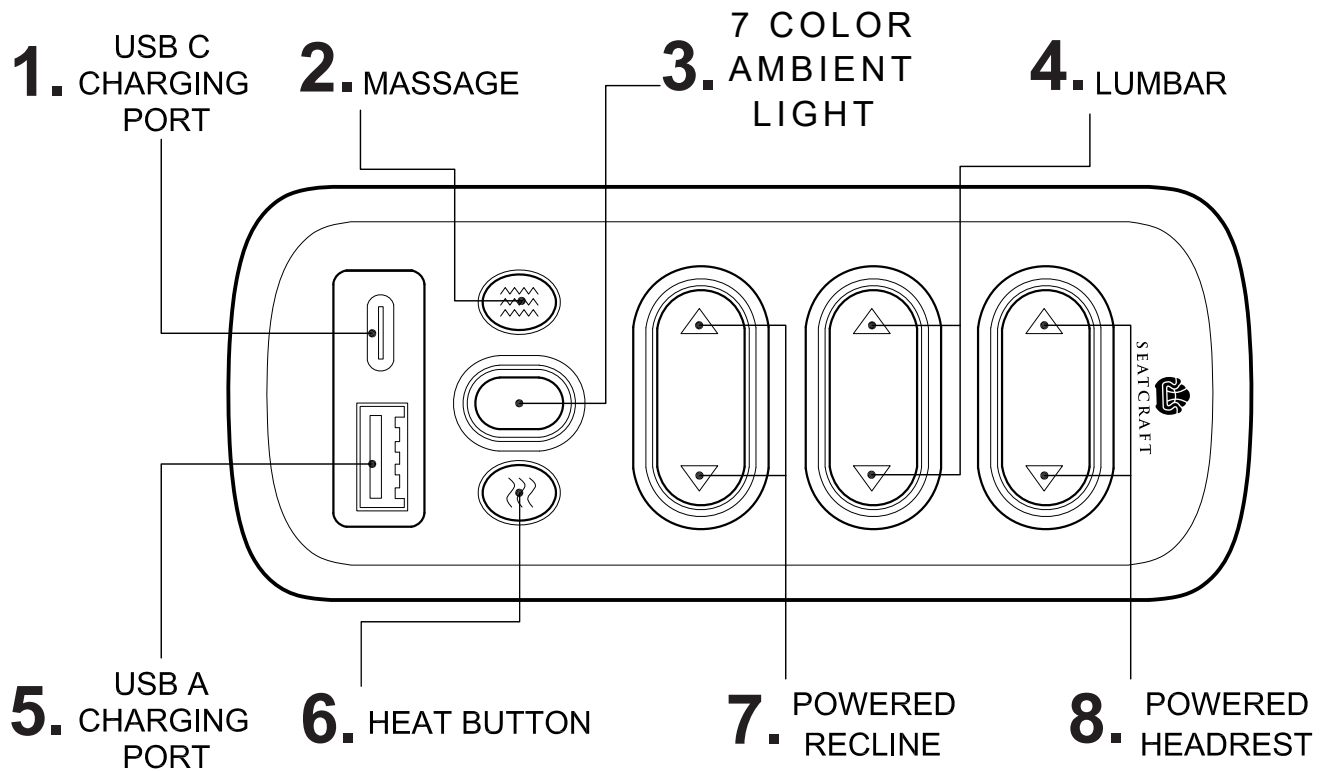

- 1. USB C CHARGING PORT**
Plug in any USB C powered device
- 2. MASSAGE**
Turn massage zones on/off when pressed
- 3. 7 COLOR AMBIENT LIGHT**
This button controls the ambient base lighting and the lighted cupholders on each armrest. Press and hold for 4 seconds to cycle through the colors.
- 4. LUMBAR**
Push to adjust the massage airbag to your preferred position.
- 5. USB A CHARGING PORT**
Plug in any USB A powered device
- 6. HEAT BUTTON**
Turn Heat zones on/off when pressed
- 7. POWERED RECLINE**
Adjust your seat to any desired position with the push of a button!
- 8. POWERED HEADREST**
These power headrests can adjust to a number of different positions with ease, reducing neck and shoulder strain.

Trouble shooting Guide

Q. Why doesn't my chair have power?

A. The Power Adapter has become loose or disconnected.

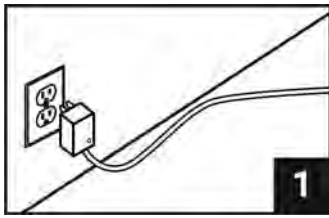

Unplug and re-plug in the Power Adapter to a wall outlet.

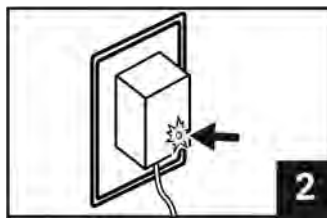

The green light on the Power Adapter should be illuminated.

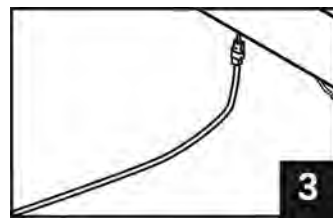

Unplug and re-plug in the Power Adapter Cable into the Seat Base Power Cable.

Q. Why aren't my chair's power features functioning?

A. The Power Cable Connection has become loose or disconnected.

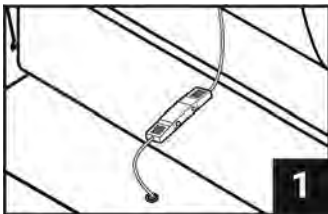

Unplug and re-plug the **Power Cable Connection** to each other.

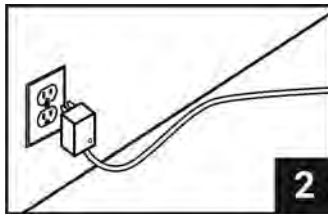

Unplug and re-plug in the Power Adapter to a wall outlet.

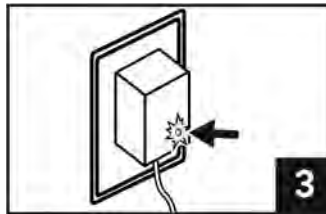

The green light on the Power Adapter should be illuminated.

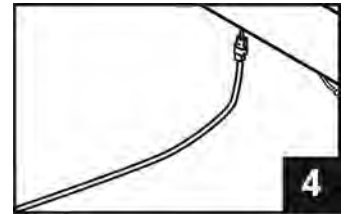

Unplug and re-plug in the Power Adapter Cable into the Seat Base Power Cable.

Trouble shooting Guide

Q. Why aren't my chair's Massage Features functioning?

A. The Massage Cable Connection has become loose or disconnected.

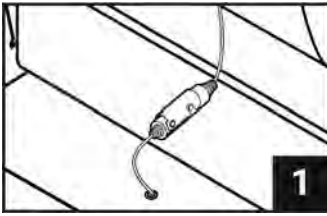

Unplug and re-plug the **Massage Cable Connection** to each other.

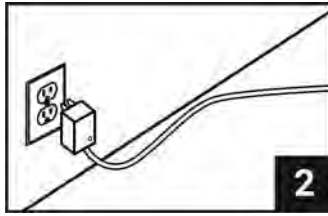

Unplug and re-plug in the Power Adapter to a wall outlet.

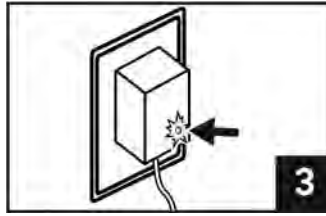

The green light on the Power Adapter should be illuminated.

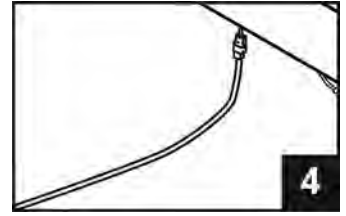

Unplug and re-plug in the Power Adapter Cable into the Seat Base Power Cable.

Q. Why aren't my chair's Massage Remote functioning?

A. The Massage Remote Cable Connection has become loose or disconnected.

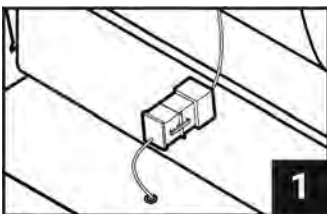

Unplug and re-plug the **Remote Cable Connection** to each other.

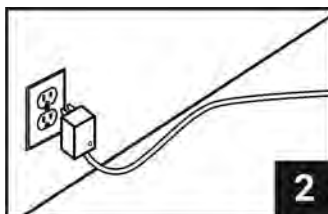

Unplug and re-plug in the Power Adapter to a wall outlet.

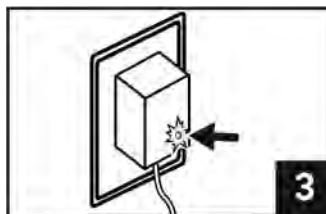

The green light on the Power Adapter should be illuminated.

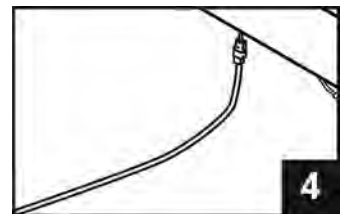

Unplug and re-plug in the Power Adapter Cable into the Seat Base Power Cable.

Trouble shooting Guide

Q. How do I remove the backrest from the seat base?

A. The Backrest Female Bracket has a locking tab.

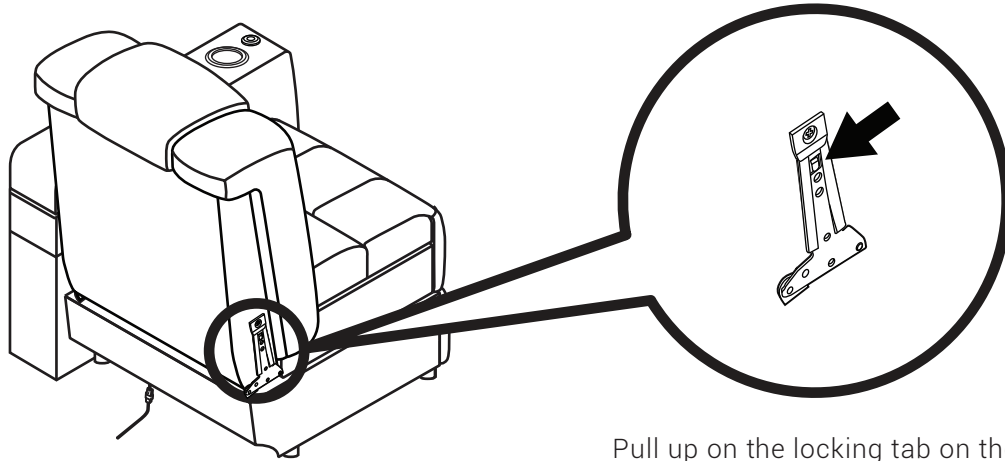

Pull up on the locking tab on the Backrest Female Bracket and firmly pull the backrest upward.

Seatcraft 4214 Sofa LAF with Heat, Massage, Power Headrest, Power Lumbar, & Power Recline 8409

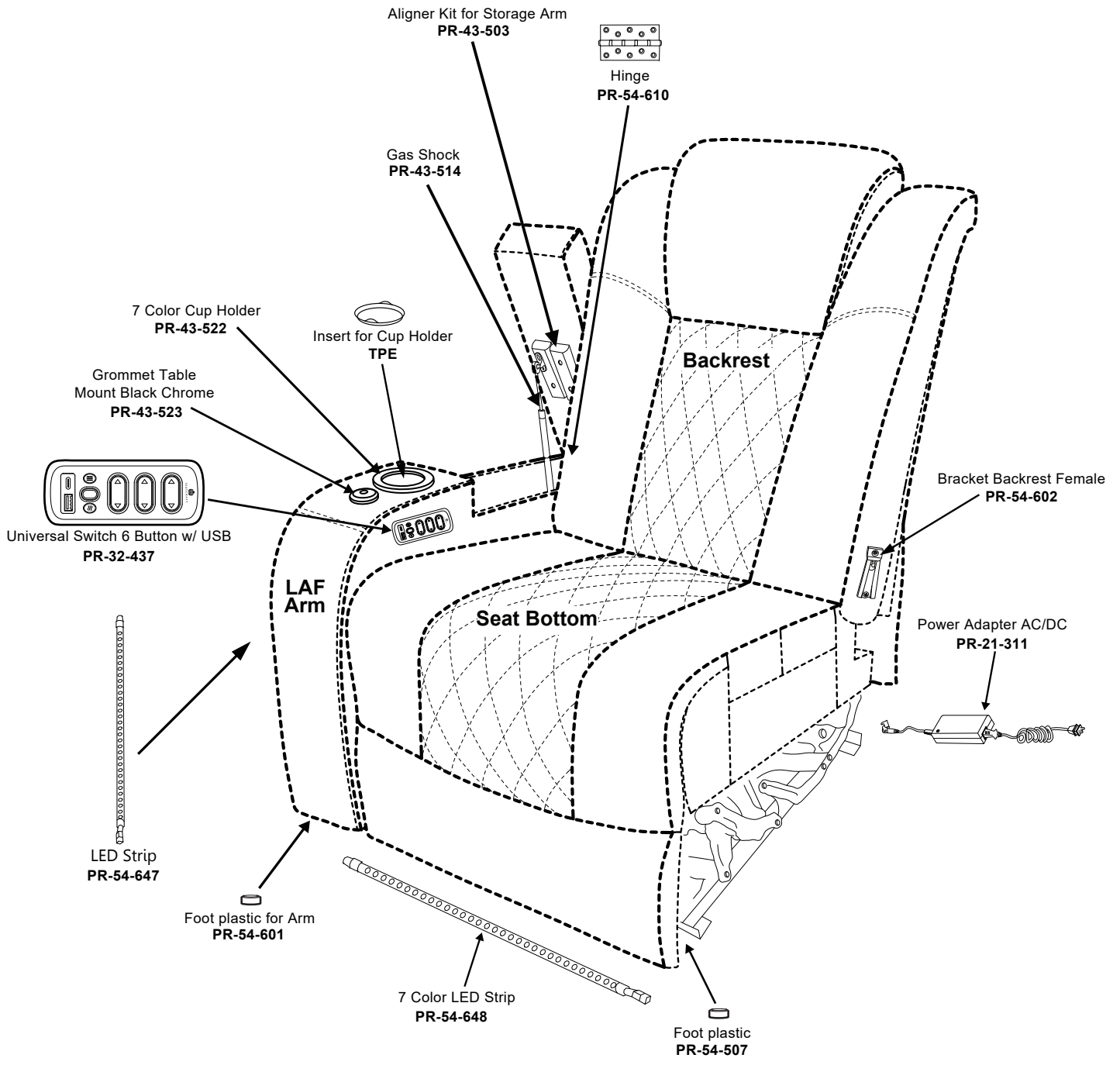

Mechanism for Recline	PR-65-736
Motor Recliner	PR-65-738

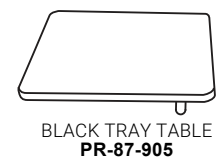

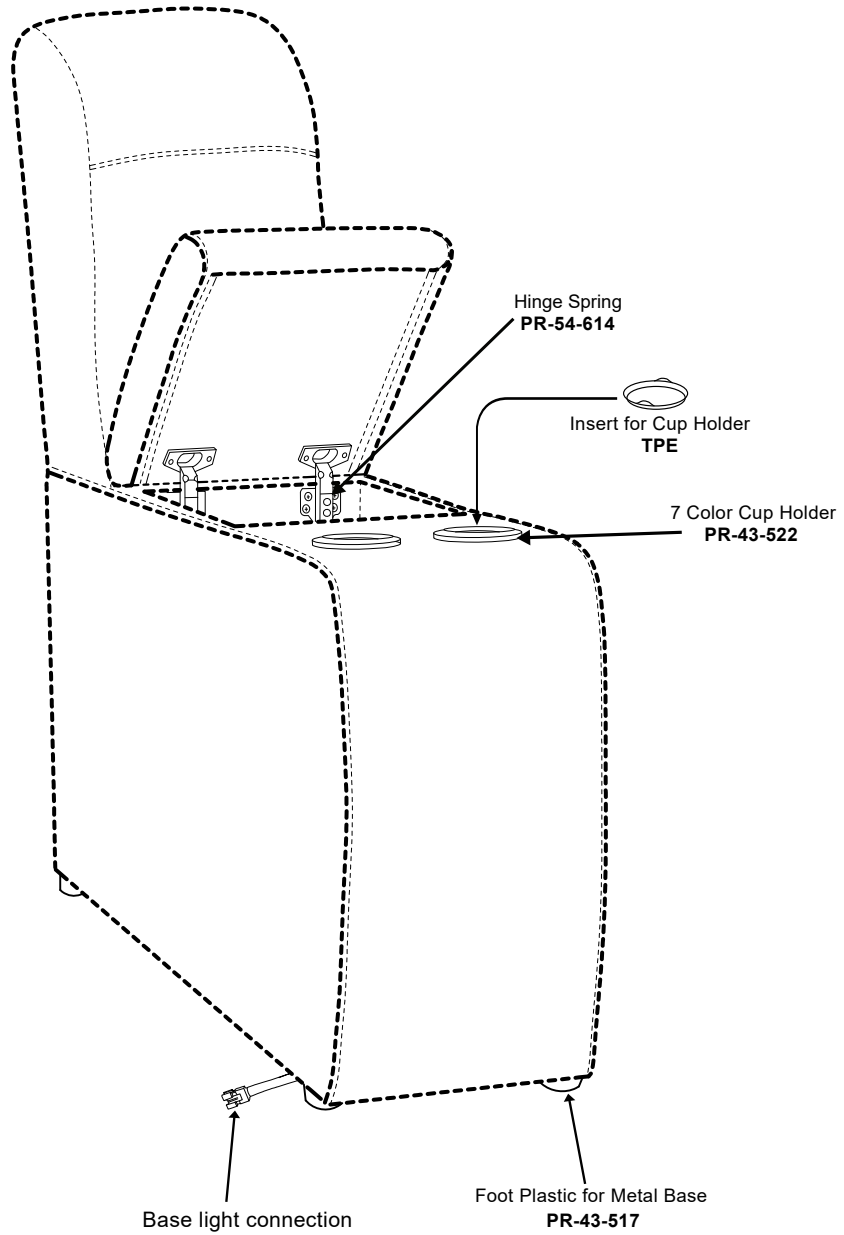

Seatcraft 4214 Sofa RAF with Heat, Massage, Power Headrest, Power Lumbar, & Power Recline

8409

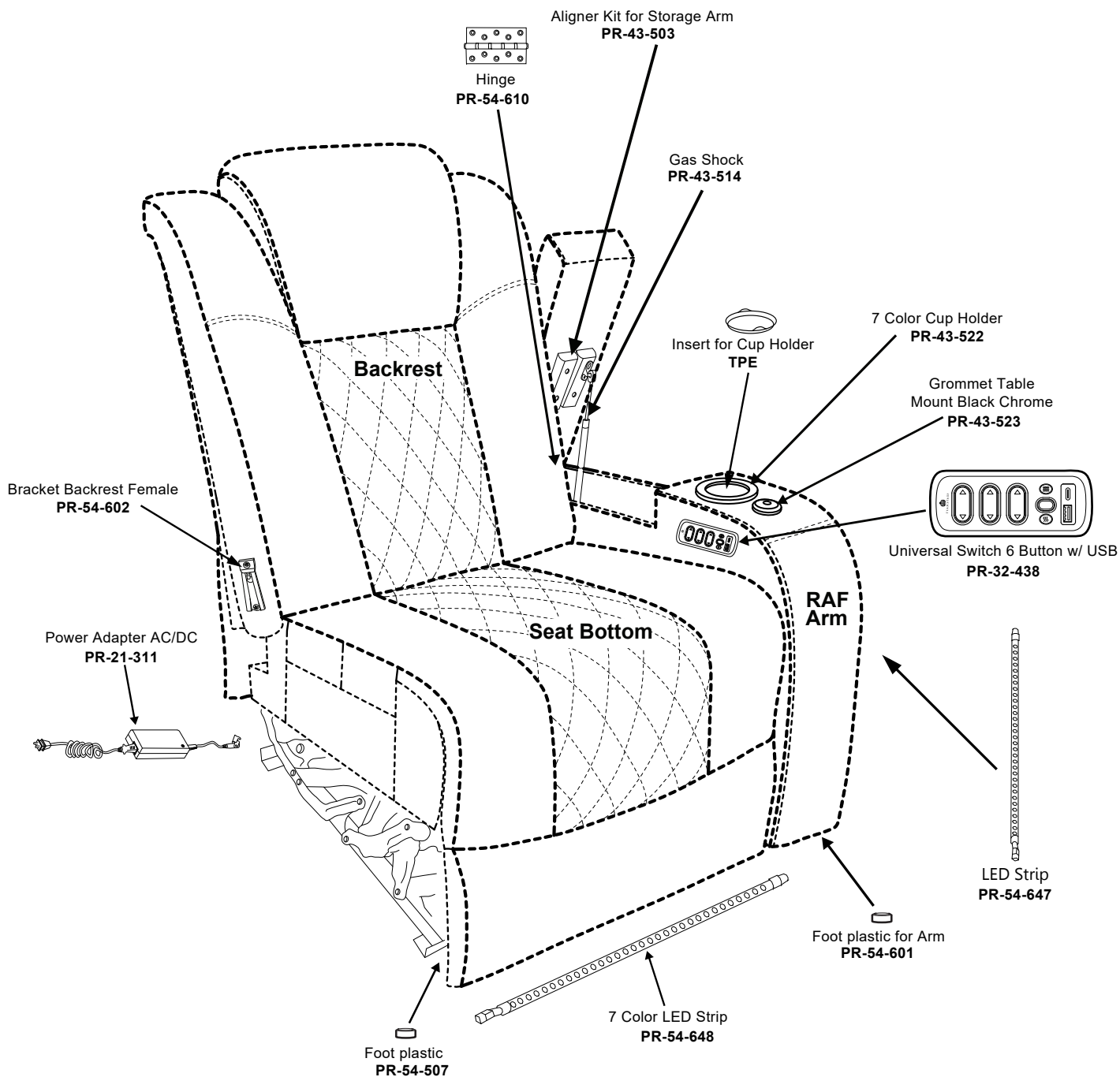

Mechanism for Recline	PR-65-736
Motor Recliner	PR-65-738

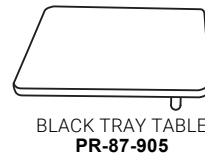

Proposition 65 Information

Q. What is Proposition 65?

A. You might have seen Proposition 65 warning labels at hotels, banks, restaurants, and even at theme parks. Proposition 65 is a California law that requires warning labels on products that may contain one of more than 800-plus chemicals or ingredients that the California Office of Environmental Health Hazard Assessment (OEHHA) has deemed to cause cancer or other reproductive toxicity. Chemicals and elements on this list include saw dust, brass, and other everyday substances, which can be found in very common household items, such as lamps, tableware, jewelry, crystal glasses, electric cords, beauty products, automobiles, and furniture.

Q. Why did I find a Proposition 65 warning on my furniture product?

A. This warning label is very common and can be found on almost every piece of furniture sold in the state of California. By law the state of California requires that we include a Proposition 65 warning on all of our products.

Important Safety Instructions

DANGER

TO REDUCE THE RISK OF ELECTRIC SHOCK OR SERIOUS INJURY:

- Disconnect the electrical plug from the wall outlet before cleaning, moving, servicing or when not in use for an extended period of time.
- Do not use this product if it is wet, in water, around water or any liquid.

WARNING

TO REDUCE THE RISK OF BURNS, FIRE, ELECTRIC SHOCK OR SERIOUS INJURY.

- Do not operate the unit until the back is installed and locked.
- Closely supervise children and disabled persons using this product.
- This product has many moving parts, serious injury can occur if not used properly. Keep children and pets away from the mechanism. Keep hands, fingers and body parts away from the mechanism.
- Sit down in the unit slowly. To avoid tip over, do not throw your weight against the back of the unit. Move the unit into or out of the reclining position slowly, making sure that no children or pets are in close proximity.
- Only the occupant should operate the unit. Never attempt to open the leg rest by pulling on it.
- Do not stand, sit or place extra weight on the arms, back or open leg rest.
- To safely exit the unit and prevent a tripping hazard bring the back upright and close the leg rest.
- Provide a clear path for operation of the chair, back and leg rest. Place tables and area rugs at a distance to allow the leg rest to fully extend without rubbing or interference.
- Keep hands, arms and body parts away from the open area between a reclined back and an upright back on a motion sofa. This area must remain clear at all times to provide unobstructed movement and prevent injury that could occur when a reclined back is returning toward the upright position.
- Use care when moving the product. Before lifting the product, secure the mechanism to prevent unexpected opening or movement. Never move the product by the mechanism, leg rest, handle, reclining back or swivel base. Disconnect modular units. Securely grip non-moving parts only.
- Do not use this product if it is damaged. Do not use attachments or substitute parts.
- Check the condition of the power transformer, electrical cord, plug, and connectors regularly. Keep the power transformer and electrical cords away from heat sources. Never operate the unit with a damaged power transformer, electrical cord, plug or connector.
- Do not use unit if power control is damaged or wet. Do not use unit if the hand wand has been dropped in water or any liquid.
- This product is not intended for use as a healthcare device.
- Users of medical devices should contact their healthcare provider before using this product. Do not use this product if you have poor circulation, are immobile or cannot sense heat, except as directed by your healthcare provider.
- This product is intended for indoor residential use only.
- Always keep open flame and lit cigarettes away from upholstered furniture. Upholstered furniture may burn rapidly with toxic gas and thick smoke.

Warranty Information

Seatcraft is proud of its high standards of quality and workmanship that go into our products. The customer is protected by the following Limited Warranty, which applies to seats under normal indoor residential use. This warranty does not apply to seats used for commercial, institutional, or other non-residential uses.

ONE YEAR LIMITED WARRANTY: Seatcraft provides (1) one year comprehensive coverage for all components such as materials, foam and frame parts, and mechanisms including motorized parts from defective materials or workmanship.

MATERIAL: Normal fabric fading, shrinking, or stretching is not covered by this warranty. Similarly, the natural markings, stretching, and shrinking of leather is a proud mark of authenticity and therefore not covered by this warranty. Evidence of improper cleaning, abuse, or abnormal use of the materials will void this warranty.

FOAM AND FRAME PARTS: Seatcraft warrants these components for (1) one year from the time of delivery, against manufacturing defects. Foam compression is natural, and therefore not covered by this warranty.

MECHANISMS: Seatcraft warrants these components for (1) one year from the time of delivery, against manufacturing defects. After the warranty period, the customer is responsible for inspection, labor and transportation costs.

No warranties, express or implied, apply after the expiration of this Limited Warranty. The warranty period covers repair, substitution, and replacement. No returns or refunds are covered. A proof of purchase is required to service a claim; simply present the bill of sale to the dealer from whom the item was purchased, to request warranty service. Seatcraft is not liable for incidental or consequential damages occurring outside the terms of this warranty, even if advance knowledge of such damages was possible.

Contact Information

We're here to help. For any missing or damaged parts or installation assistance please call us at 1-855-244-0170.

HOURS

Mon-Fri	6AM - 7PM PST
Sat	9AM - 5PM PST
Sun	10AM - 5PM PST